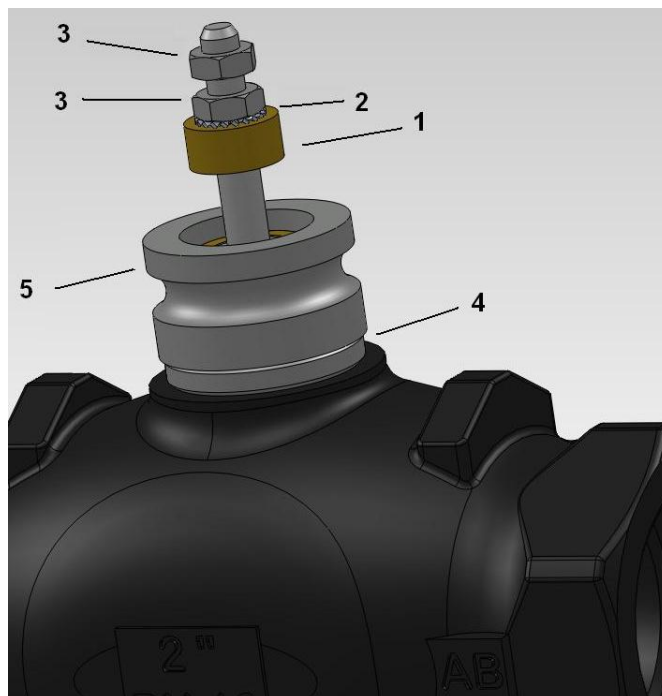

MOUNTING INSTRUCTIONS

**Mounting the Joint**

- Unscrew the ring nut on the thread of the valve neck, and remove the stem protection (if present);
- insert the spacer **(1)** on the valve stem placed with the hollow side downwards;
- insert the theethed washer **(2)** on the valve stem;
- screw down completely nut **(3)** on the valve stem until it reaches the spacer, but without tightening it;
- screw the further nut **(3)** on the valve stem; this will function as counter nut to fix the MVExS actuator;
- insert the washer **(4)** on the valve neck;
- screw joint **(5)** on the valve neck and make sure it is tightened completely on the thread.

Actuator Mounting

- Mount the actuator on the valve according to the actuator mounting instructions.