

**eliwell**

# **FC PLUS** **Fan Coil Controller**



# 1 CONTENTS

1	<i>Contents</i>	2
2	<i>How to use this manual</i>	4
3	<i>Introduction</i>	5
3.1	<i>General Description</i>	5
3.1.1	<i>FCPLUS</i>	5
3.2	<i>Interface</i>	6
3.2.1	<i>FCPLUS interface</i>	6
3.3	<i>Example of fan-coil system</i>	6
3.4	<i>Models available</i>	7
3.4.1	<i>FC PLUS Models</i>	7
3.4.2	<i>How to order FCPLUS</i>	7
3.5	<i>Accessories</i>	8
3.6	<i>Characteristics for selecting product models:</i>	8
3.6.1	<i>Table of FCPLUS characteristics</i>	8
3.7	<i>Dip Switches</i>	9
4	<i>Installation</i>	10
4.1	<i>Recommendations</i>	10
4.2	<i>Mounting</i>	10
4.3	<i>Wiring diagrams</i>	11
4.3.1	<i>Wiring recommendations</i>	11
4.4	<i>Outputs</i>	11
	OUT1	12
	OUT2	12
4.5	<i>Inputs</i>	13
4.5.1	<i>FC PLUS</i>	13
4.6	<i>Analogue inputs</i>	14
4.6.1	<i>Analogue inputs/Probes</i>	14
4.6.2	<i>Temperature set point</i>	15
4.7	<i>Digital outputs</i>	15
4.8	<i>Dip Switches</i>	15
4.8.1	<i>Characteristics of machine</i>	16
4.8.2	<i>Dip Switch Configuration</i>	17
4.8.3	<i>Dip 4-5 configuration</i>	17
4.8.4	<i>DIP 3 Configuration</i>	18
5	<i>User interface</i>	19
5.1	<i>Set point selector knob - FC PLUS</i>	19
5.1.1	<i>Clicking of selector knob</i>	19
5.1.2	<i>Control of range</i>	19
5.2	<i>Sliders</i>	20
5.2.1	<i>Fan control slider</i>	21
5.2.2	<i>Operating mode slider</i>	21
5.3	<i>LEDs</i>	21
5.3.1	<i>Table of Functions and Indications associated with LEDs</i>	21
6	<i>Temperature control functions</i>	23
6.1	<i>Operating modes</i>	23
6.2	<i>Control</i>	23
6.2.1	<i>Summary of Dip Switches</i>	23
6.2.2	<i>Thermostat control on fan/valve</i>	23
6.3	<i>Thermostat control on valve</i>	24
6.3.1	<i>AUTO FAN – temperature control on valve</i>	25
6.3.2	<i>Thermostat control on fan</i>	26
6.3.3	<i>AUTO FAN with temperature control on fan</i>	26
6.3.4	<i>Load control</i>	28
6.3.5	<i>Electric heaters</i>	28
7	<i>Functions</i>	29
7.1	<i>Automatic Change over</i>	29
7.2	<i>Hot Start</i>	30

7.3	<i>Too Cool</i> .....	31
7.3.1	<i>Blocking Hot-Start and Too- Cool functions from Power –On</i> .....	31
7.4	<i>Periodic ventilation</i> .....	31
7.4.1	<i>Fan activation cycles in HEAT Mode</i> .....	32
7.4.2	<i>Fan activation cycles in COOL Mode</i> .....	32
7.5	<i>Post Ventilation</i> .....	32
7.6	<i>Set point Decalibration</i> .....	32
7.7	<i>Economy / Window Contact</i> .....	32
7.7.1	<i>Economy (E)</i> .....	32
7.7.2	<i>Window Contact (W)</i> .....	33
8	<i>Parameters</i> .....	34
8.1	<i>Table of configuration constant values (parameters)</i> .....	34
9	<i>Technical Data</i> .....	37
9.1	<i>Technical Data</i> .....	37
9.1.1	<i>FCPLUS General Technical Data</i> .....	37
9.1.2	<i>FCPLUS I/O Technical Data</i> .....	37
9.1.3	<i>FCPLUS Mechanical Technical Data</i> .....	37
9.2	<i>Dimensions (mm)</i> .....	38
9.3	<i>Declaration of compliance</i> .....	39
10	<i>Use of device</i> .....	40
10.1	<i>Permitted Use</i> .....	40
11	<i>Responsibility and residual risks</i> .....	41
12	<i>Disclaimer</i> .....	42
13	<i>Glossary</i> .....	43

## 2 HOW TO USE THIS MANUAL

This manual is designed to permit quick, easy reference with the following features:

### References

#### **References column:**

A column to the left of the text contains *references* to subjects discussed in the text to help you locate the information you need quickly and easily.

### Cross references

#### **Cross references:**

All words written in *italics* are referenced in the subject index to help you find the page containing details on this subject; supposing you read the following text:

"when the alarm is triggered, the compressors will be shut down"

The italics mean that you will find a reference to the page on the topic of compressors listed under the item compressors in the index.

If you are consulting the manual "on-line" (using a computer), words which appear in italics are hyperlinks: just click on a word in italics with the mouse to go directly to the part of the manual that discusses this topic.

### Icons for emphasis:

Some segments of text are marked by icons appearing in the *references* column with the meanings specified below:



**Take note:** information on the topic under discussion which the user ought to keep in mind



**Tip:** a recommendation which may help the user to understand and make use of the information supplied on the topic under discussion



**Warning! :** information which is essential for preventing negative consequences for the system or a hazard to personnel, instruments, data, etc., and which users **MUST** read with care.

## 3 INTRODUCTION

### 3.1 General Description

#### 3.1.1 FCPLUS

**FCPLUS** is an electronic controller for fan-coils designed to *control* valves with on-off actuators, electrical heaters if present and the three fan speeds. Once the unit has been set correctly, it controls the following fan coil units:

- 2 pipes
- 2 pipes with *electric heaters*
- 4 pipes
- independent wall thermostat
- ceiling-mounted installations
- floor-mounted fan coil installations

In all cases, automatic *control* of the three fan speeds based on the *offset* between the ambient temperature and the *set point* is possible.

#### Typical applications

- Household
- Residential
- Small commercial areas (offices, hospitals, hotels)

#### Main characteristics

- One family that is now even more comprehensive with a simple modern design
- One controller for a variety of system and machine requirements;
- Easy to use and install
- Less risk of damaging electronics
- Maximum focus on comfort and energy savings
- *Hot Start*
- *Too Cool*
- *Post ventilation*
- *Periodic Ventilation*
- Economy Input or Window Contact
- Automatic fan speed
- Low noise level with solid state technology
- *Control of range.....*
- Ventilation selectable in *dead zone*
- Remote air probe (optional accessory)
- Vertically installed for easier on board-*installation*
- Operating and probe alarm *LEDs*

FCPLUS

### 3.2 Interface

#### 3.2.1 FCPLUS interface



#### Knob

- Gamma *Set point*: from 5° to 35°C with  $\pm 0.5^\circ$  stop-click;
- plugs to limit *set point range* or block it at a specific value

#### Slide switches\*

- 1 fan switch to *control* fan speed: High/Medium/Low/*Auto*
- 1 switch to select mode: OFF/*Heating*\*\*/*Cooling*\*\*\*/*Auto*

#### LEDs

- *Heating* LED (red)
- *Cooling* LED (green)
- Thermostat request LED (yellow)

**NOTE:** \* Slide switches are also referred to in the text as *Sliders*  
\*\* *Heating* is referred to as **HEATING** or **WINTER** mode  
\*\*\* *Cooling* is referred to as **COOLING** or **SUMMER** mode

### 3.3 Example of fan-coil system

A typical fan-coil system with 2 and 4 pipes can be seen in the diagram below:

2 pipe system

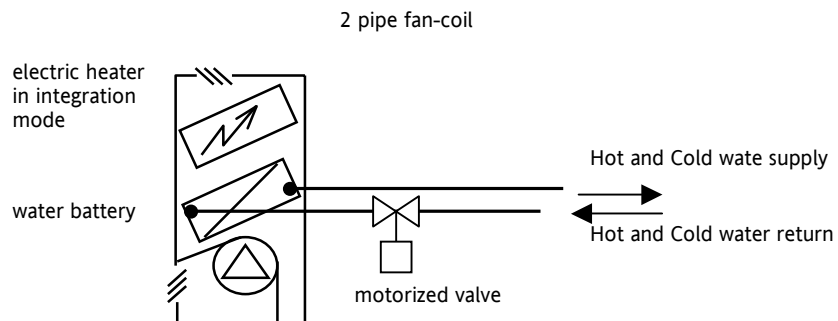

4 pipe system

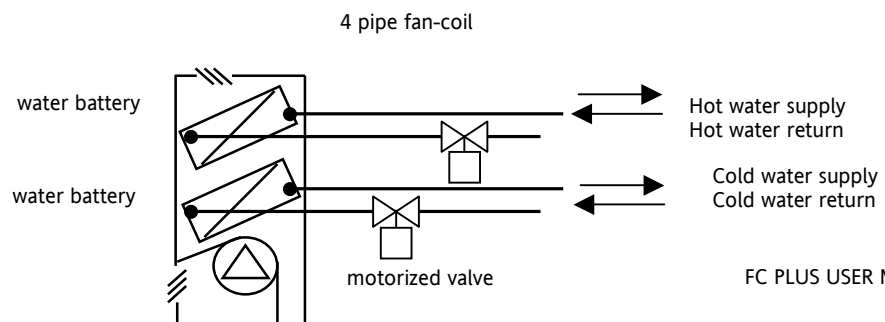

**Control of Fan**

**OUTLET FAN**

The fan is situated immediately in front of the *finned coil*; it works by taking up the ambient air using the inlet duct. The air passes through the battery and is then emitted into the environment.  
If the controller is installed on the fan-coil unit itself, another return air probe situated in the inlet air flow measures the ambient temperature. However, in this case, the measurement is only valid if there is enough inlet air flow to prevent or reduce stratification in the environment.

**Finned coil**

**WATER COIL – MOTOR-DRIVEN VALVE**

It consists of a water-air exchanger placed in the internal environment that the inlet air flow passes through. The exchanger is supplied with hot or cold water normally produced by a chiller or boiler.

**Valve**

A double supply circuit for the coil (4 pipes) is possible. The 4 pipe configuration requires two motor-driven valves and two independent exchangers or one single exchanger (2 pipes). It is often important to determine the temperature of the battery supply water. A water probe placed on the downstream side of the coil and *valve* return is used for this purpose.

**Electric heaters**

**ELECTRIC HEATERS**

The electric coil can be used to heat the air if hot water is not available or contribute to *heating* water when there is not enough.

**3.4 Models available**

**3.4.1 FC PLUS Models**

**FP U320/B**

The ideal model for wall-*mounting*; automatically controlled fan speed

**FP U32E/B**

Basic model with economy input

**FP U32W/B**

Basic model with window contact

**FP U320/S**

Universal model with remote probe *inputs*

**FP U32E/S**

Universal model with economy input that moves the *set points* to 14 ° C during winter operating and 28 °C during summer operating if enabled

**FP U32W/S**

Universal model with window contact that when enabled puts the controller on *stand-by* until the window is closed.

Refer to the summary table below:

**Table of models**

**Explanation of product codes:**

Number	Code	Description
<b>Model</b>	<b>FP</b>	<b>PLUS fan coil</b>
1°	U	Universal model, fan coil system with 2 or 4 pipes selectable
2°	3	2 slide switches: Off / <i>Heating</i> / <i>Cooling</i> / Automatic & Ventilation Low / Medium / High / Automatic
3°	2	Presence of electric <i>heating</i> selectable
4°	0 E W	No voltage input Economy input present Window Contact input present
5°	/B /S	Basic Model – without remote probes Model with <i>remote water and air probe inputs</i>

**3.4.2 How to order FCPLUS**

Here is a list of available models with the *item code* required to order.

**Item Code**

***Item Code***

Model	Item Code
FP U320/B	FP 10B 0 00 05 00
FP U320/S	FP 10S 0 00 05 00
FP U32E/B	FP 1EB 0 00 05 00
FP U32E/S	FP 1ES 0 00 05 00
FP U32W/B	FP 1WB 0 00 05 00
FP U32W/S	FP 1WS 0 00 05 00

Remote water and air probe

3.5 Accessories

Remote water and air probe

- NTC temperature probe, plastic cover 7x25, reinforced insulation, PVC cable, cable length = 1.5m
- NTC temperature probe, plastic cover 6x40, reinforced insulation, PVC cable, cable length = 1.5m

3.6 Characteristics for selecting product models:

3.6.1 Table of FCPLUS characteristics

Model	FP U320/B	FP U32E/B	FP U32W/B	FP U320/S	FP U32E/S	FP U32W/S
<b>Application</b>						
2 pipes	*	*	*	*	*	*
2 pipes with integrated <i>electric heaters</i>						
2 pipes with regulated <i>electric heaters</i>	*	*	*	*	*	*
4 pipes	*	*	*	*	*	*
<b>Installation</b>						
Wall-mounted	(°)	(°)	(°)	(°)	(°)	(°)
Device-mounted – ceiling	*	*	*	*	*	*
Device-mounted – floor	*	*	*	*	*	*
<b>Inputs/Outputs</b>						
Digital <i>Inputs</i>	-	1	1		1	1
Air probe	1	1	1	1	1	1
Remote air probe (not supplied)	-	-	-	1	1	1
Remote water probe (not supplied)	-	-	-	1	1	1
230Vac <i>Triac outputs FAN</i>	3 (1 A max)	3 (1 A max)	3 (1 A max)	3 (1 A max)	3 (1 A max)	3 (1 A max)
230Vac <i>Triac outputs VALVE</i>	2 (0.5 A max)	2 (0.5 A max)	2 (0.5 A max)	2 (0.5 A max)	2 (0.5 A max)	2 (0.5 A max)
<i>LEDs</i>	3	3	3	3	3	3
<b>Functions</b>						
<i>Hot Start</i>	-	-	-	**	**	**
<i>Too Cool</i>	-	-	-	**	**	**
Economy Input	-	•	-	-	•	-
Window Contact	-	-	•	-	-	•
Operating/probe alarm <i>LEDs</i>	•	•	•	•	•	•

Notes:

- compatible
- \* dip-switch selectable
- \*\* only if remote water probe is present
- (°) machine configuration (wall-mounted) automatically identified if the remote air probe is not installed

Characteristics common to all models

- *Functions*
- manual change-over
- *automatic change-over*
- *Post ventilation*
- *Periodic ventilation*
- Automatic speeds
- *Control of set point*
- Ventilation in *dead zone* (\*)
- Regulation on valves/fans

(\*) dip-switch selectable

### 3.7 Dip Switches

DIP Number	Description	On	Off
1	Type of <i>installation</i>	Ceiling-mounted	Floor-mounted
2	Ventilation	continuous (1)	on request (2)
3	Thermostat <i>control</i>	On <i>valve</i>	On fan
4 and 5	Type of system		
	2 pipes without <i>electric heaters</i>	-	4; 5
	2 pipes with integrated <i>electric heaters</i>	4; 5	-
	2 pipes with regulated <i>electric heaters</i>	5	4
	4 pipes	4	5

(1) no *Hot Start* and *Too Cool*

(2) on request in heat mode; continuous in cool mode

## 4 INSTALLATION

The **FCPLUS** wall-mounted version consists of two parts:

- the first (connector base unit) is fastened to the wall and contains the connectors;
- the second (main **interface**) contains the electronics and all the controls and can be connected to the first part with a simple snap-on connector.

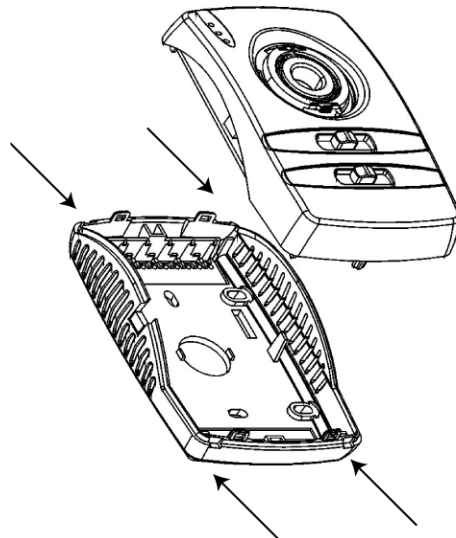

This makes **installation** easy and prevents damage to the electronic parts during **installation**.

Use a small screwdriver to separate the connector base unit from the main **interface**. Place the screwdriver in the special holes (in the side of the casing) and twist slightly until the two parts come apart.



**FCPLUS** can also be installed in a fan-coil unit.

An additional remote air probe must be installed in the return air flow of the unit.

### 4.1 Recommendations

In normal operating conditions, parts with dangerous voltage levels must not be accessible to users.

The device must be adequately protected from water and dust.

Avoid assembling the controller in environments with the following characteristics:

- Relative humidity above 90%, non-condensing
- Strong vibrations or knocks
- Exposure to continuous jets of pressurized water
- Exposure to aggressive and polluting atmospheres that may cause corrosion and oxidation (e.g. sulphuric or ammoniacal substances, salt mist, fumes)
- Presence of high magnetic or radiofrequency interference (e.g. near transmitting antennas)
- Exposure to direct sunlight or atmospheric agents.

When connecting controllers to each other or **accessories**, electric **loads** and other devices, pay special attention to the following:

- Incorrectly connected supply voltage may damage the controller.
- Suitable wire terminals for connectors must be used. Unscrew the terminal screw, insert the wire terminal and fasten the screw. Check fastening by lightly pulling the cable. Do not use automatic starters (or adjust them to a torque below 50 N\*cm)
- Potential electromagnetic interference: use separate cables for high and low voltage **loads**. Keep the temperature probe cables and digital **inputs** as far apart as possible from cables with inductive or power **loads**.
- Never place the power cables and temperature probe cables in the same conduit. The remote probe cables must be kept away from the power devices (e.g. power **TRIAC**). The distance covered by these cables must be kept to a minimum.
- Never apply **loads** exceeding those indicated in this specification to the **outputs**.
- When connecting **loads**, carefully observe the load **wiring diagrams**

### 4.2 Mounting

The controller must be mounted in a place where:

- The controller can be easily accessed
- There are no blinds, cabinets, shelves, etc....
- Free circulation of air is guaranteed

- There is no direct sunlight
- There are no draughts (e.g. open doors or windows)
- It does not come into contact with sources of heat and *cooling*
- There is no external wall
- It is installed on the wall at approx. 1.5 m above floor level

### 4.3 Wiring diagrams

#### 4.3.1 Wiring recommendations

The device has screw connectors for connecting cables with a maximum cross-sectional area of 1.5 mm<sup>2</sup> (for power contacts; only one conductor per terminal).

Always switch off machine before working on electrical *connections*. Make sure that the power voltage complies with the device voltage. Only use supplied screws. Do not install the device on metal surfaces. Do not insert objects of any kind into the slots of the device (regardless of whether the device is on or off).

The probe requires no connection polarity and can be extended using an ordinary bipolar cable (note that if the probe is extended, this affects the electromagnetic compatibility of the instrument: special care must be used when wiring. Only use the supplied probes).

Make sure there is a minimum distance of 8 mm between the instrument components/*accessories* and the accessible parts (cables, sensors, etc.).

#### Connections

The *loads* must be connected to the *FCPLUS* as shown below:

#### Terminal block diagram

*Terminal block diagram*

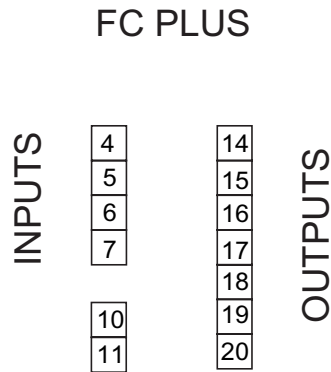

### 4.4 Outputs

#### Outputs

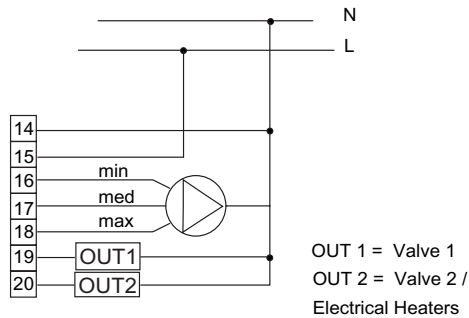

OUTPUT	APPLICATION		
	<i>2 pipe system only</i>	<i>2 pipe system with electric heater</i>	<i>4 pipe system</i>
OUT1	Not used	<i>Heating/Cooling Valve</i>	<i>Cooling Valve</i>
OUT2	<i>Heating/Cooling Valve</i>	Electric heater	<i>Heating valve</i>

## 4.5 Inputs

### 4.5.1 FC PLUS

FP U320S

#### FP U320/S

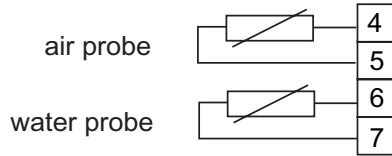

#### *FP U320S*

FPU32E/B

#### *FPU32E/B*

#### FP U32E/B



FPU32E/S

#### *FPU32E/S*

#### FP U32E/S

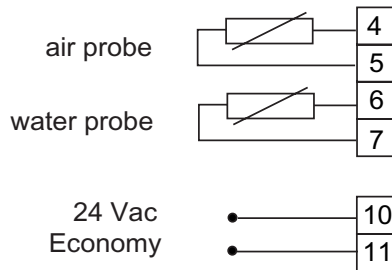

## FP U32W/B

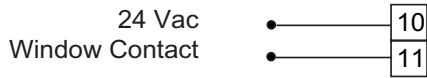

## FP U32W/S

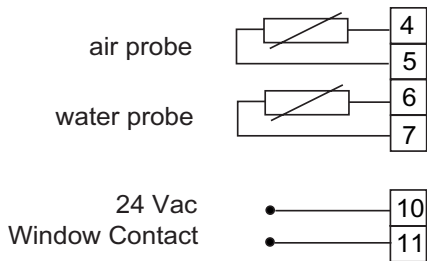

### 4.6 Analogue inputs

#### 4.6.1 Analogue inputs/Probes

Three *analogue inputs* are available:

Number	Description	Probe range	Measurement range
ST1	Ambient temperature probe (always internal) Probe mounted on board in wall-mounted installations.	-50°C +100°C	-50°C +110°C
ST2	Optional sensor; it inhibits operating of ST1 if present. Used for regulating ambient temperature, it is mounted on the device in ceiling-mounted or floor-mounted installations. For information on <a href="#">connections</a> , see diagram.	-50°C +100°C	-50°C +110°C
ST3	Optional probe; it enables <a href="#">Hot Start</a> and <a href="#">Too Cool functions</a> when present. This sensor, which must be installed on the downstream side of the water <a href="#">valve</a> , is used to <a href="#">control</a> the water temperature.	-50°C +100°C	-50°C +110°C

**Note:** *inputs* 1 and 2 are expressed to the nearest ten degrees Celsius with reference to 0 (zero) Celsius.

If the measurement *range* is exceeded, the probe is considered faulty.

Measurement resolution is 1/4 di C°.

Measurement error is:

- less than 1°C between +5°C and 50°C;
- less than 2°C between -20°C and 100°C;

#### 4.6.2 Temperature set point

Number	Description	Use
ST1 (selector knob)	Potentiometer input: Used to set the controller <i>set point</i> . Ranging from a minimum <i>set point</i> of 5 C° to a maximum <i>set point</i> of 35 C°.	-105° +105° from average point

**Note:** The presence of the water probe is automatically detected by the controller during start-up.

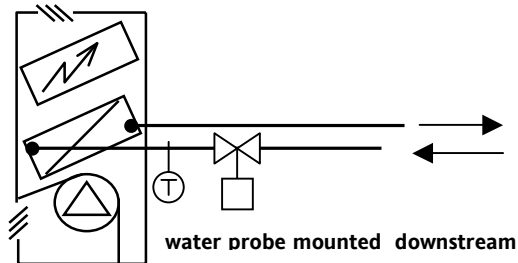

The water probe (*analogue inputs*) must always be mounted on the water pipe on the downstream side of the *valve* and as near as possible to the coil. In *4 pipe systems*, it must always be mounted on the hot water and not the cold water circuit.

#### 4.7 Digital outputs

**TRIAC** The *digital outputs* consist of 5 TRIACs

Number	Function	Description
FAN	<i>Control</i> of Outlet Fan (see Operating of fan on demand)	Starts ventilation. The fan <i>control</i> cursor takes the phase to three different terminals so that the 3 fan speeds can be manually selected.
OUT1	<i>Valve Control</i>	Allows water to flow into the coil.
OUT2	<i>Control</i> of <i>valve</i> or <i>electric heaters</i>	If the electric heater coil is present, the <i>TRIAC</i> controls it. If not, it is controlled in the same way as the second <i>valve</i> on a <i>4 pipe system</i> .

OUTPUTS	2 pipes	2 pipes with <i>electric heaters</i>	4 pipes
OUT1	<i>Heating/cooling valve</i>	Not used	<i>Cooling valve</i>
OUT2	Not used	<i>Electric heaters</i>	<i>Heating valve</i>

#### 4.8 Dip Switches

There are 5 *Dip Switches* on the back of the electronic board. Their *functions* are listed below:

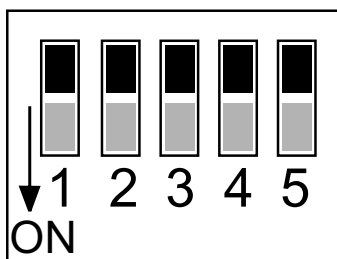

DIP 4-5

Dip Switch no.	4	5	Description
	OFF	OFF	2 pipe device without <i>electric heaters</i>
	OFF	ON	4 pipe device
	ON	OFF	2 pipe device with <i>control electric heaters</i>

	ON	ON	2 pipe device with integrated <i>electric heaters</i>
--	----	----	---

**DIP 3-2-1**

Dip no.	Switch	ON	OFF	Description
3		x		thermostat <i>control</i> on <i>valve</i>
			x	thermostat <i>control</i> on fan
2			x	ventilation on demand
		x		continuous ventilation
1			x	floor-mounted device
		x		ceiling-mounted device

**4.8.1 Characteristics of machine**

**DIP 4-5**

Dip Switch no.	4	5	2 pipes	4 pipes	<i>Electric heaters</i>	Fan speed	ST1 mandatory	<i>Heating</i>	<i>Cooling</i>	<i>Electric heaters</i>
ALL MODELS	OFF	OFF	x	-	-	3	B models	OUT1	OUT1	-
ALL MODELS	ON	OFF	-	-	-	3	B models	OUT2	OUT1	-
	OFF	ON	x	-	x	3	B models	-	OUT1	OUT2
	ON	ON	x	-	x	3	B models	OUT1	OUT1	OUT2

**NOTE:**

- indicates NOT USED

To access the *DIP switches*, proceed as follows:

- First, use a small screwdriver to separate the connector base unit from the main *interface*. Place the screwdriver in the special holes (in the side of the casing) and twist slightly until the two parts come apart.
- If you turn the back of the main *interface* around, you can see the *DIP switches* installed on the printed circuit board.

#### 4.8.2 Dip Switch Configuration

Locate the *dip switches* on the rear of the board (see Fig. position C), then configure the system according to needs.

#### 4.8.3 Dip 4-5 configuration

Table A

system	DIP no.	
	5	4
2 pipe device without <i>electric heaters</i>	OFF	OFF
4 pipe device	OFF	ON
2 pipe device with <i>control electric heaters</i>	ON	OFF
2 pipe device with integrated <i>electric heaters</i>	ON	ON

Table B

		<i>Dip Switch Configuration</i>			
		Dip4 OFF DIP5 OFF	Dip4 ON DIP5 ON	Dip4 OFF Dip5 ON	Dip4 ON Dip5 OFF
Type of system	System	2 pipes	2 pipes	2 pipes	4 pipes
	<i>Electric heaters</i>	NO	Integrated	<i>Control</i>	NO
Outputs	<i>Heating</i>	OUT 1	OUT 1	-	OUT 2
	<i>Cooling</i>	OUT 1	OUT 1	OUT 1	OUT 1
	<i>Electric heaters</i>	NO	OUT 2	OUT 2	NO

#### Dip 5-4

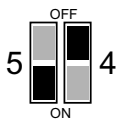

- Dip 5 = OFF
  - Dip 4 = OFF
- 2 pipe device without *electric heaters*

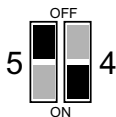

- Dip 5 = OFF
  - Dip 4 = ON
- 4 pipe device

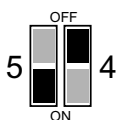

- Dip 5 = ON
  - Dip 4 = OFF
- 2 pipe device with *control electric heaters*

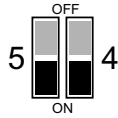

- Dip 5 = ON
  - Dip 4 = ON
- 2 pipe device with integrated *electric heaters*

#### 4.8.4 DIP 3 Configuration

Dip no.	Switch	ON	OFF	Description
3			x	thermostat <i>control</i> on <i>valve</i>
		x		thermostat <i>control</i> on fan

#### Dip 3 *Dip 3*

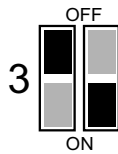

- *Dip 3* = OFF
  - *Dip 3* = ON
- thermostat *control* on fan  
thermostat *control* on *valve*

#### Dip 1-2

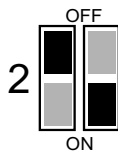

- Dip 2 = OFF
  - Dip 2 = ON
- ventilation on demand  
continuous ventilation

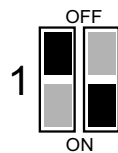

- Dip 1 = OFF
  - Dip 1 = ON
- floor-mounted device  
ceiling-mounted device

## 5 USER INTERFACE

**FCPLUS** has three main controls:

- Selector knob
- 2 *sliders*

### 5.1 Set point selector knob - FC PLUS

A potentiometer used to set the operating *set point*.

The operating *set point* varies according to the angle set from 5 to 35 degrees Celsius.

The *range* from the central point of the potentiometer is +/- 105° degrees.

#### 5.1.1 Clicking of selector knob

A sensitive mechanism that clicks approximately every 0.5°C for more accurate setting.

#### 5.1.2 Control of range

The *set point* can be controlled on all models by establishing a minimum and maximum value using 2 pegs placed underneath the selector knob. If the two pegs are assembled close to each other, the *set point* can be blocked at a specific value.

Proceed as follows:

1. Use a small screwdriver to separate the connector base unit from the main *interface*. Place the screwdriver in the special holes (in the side of the casing) and twist slightly until the two parts come apart.
2. Before going on to the next stage, turn the selector knob to its median position if you want to restrict the *range* (minimum/maximum). If you want to block the *set point*, place the selector knob in the block value position you require. If you turn the back of the main *interface* around, you can see a hole halfway along the electronic board. Lightly press the pin connected to the knob until it comes away from the main *interface*.
3. You can now remove the knob on the main *interface* touchpad and access the *range control*. Once the pegs have been placed in the required position, reassemble the selector knob correctly in the *interface*.

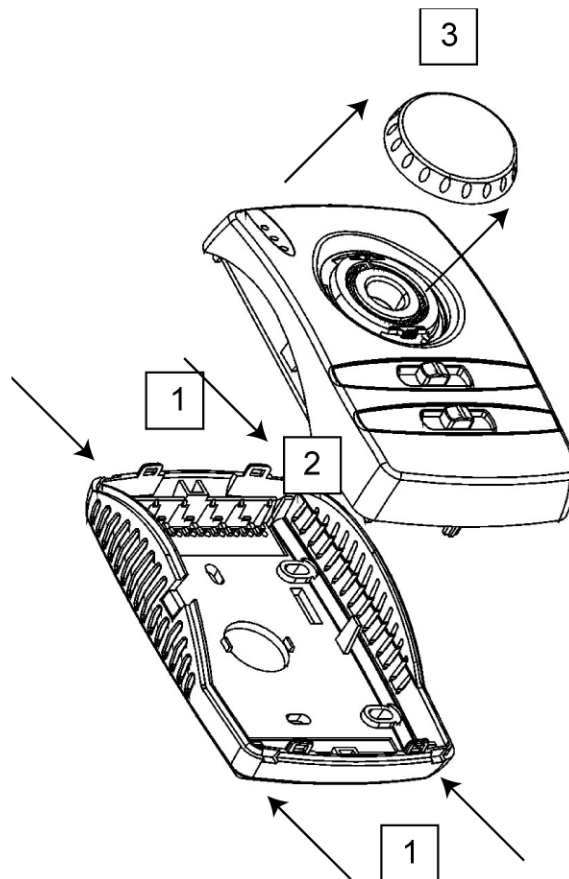

- Factory setting of limit pegs at 5°C and 35°C:
- Example of limit *range* between 15°C and 25°C:

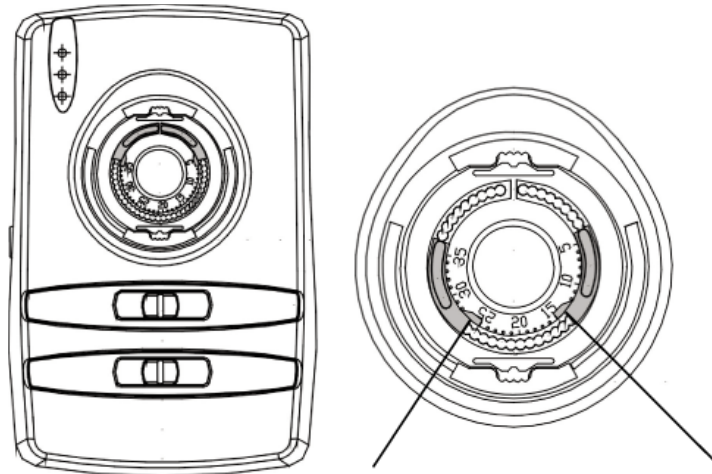

## 5.2 Sliders

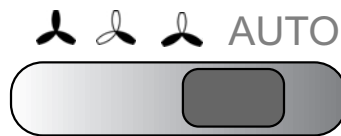

2 4-position *sliders* are supplied to select the operating mode and fan speed.

### REGULATING

The desired temperature can be regulated and set using the selector knob on the instrument keypad.

### OPERATING

*Operating modes* can be selected and set using the *slider* on the instrument keypad:



1. Device off
2. *Heating* setting
3. *Cooling* setting
4. Automatic selection setting

In the same way, the fans can be set to three different speeds or automatic mode:



1. Fans at maximum speed
2. Fans at medium speed
3. Fans at minimum speed
4. Automatic selection setting

### 5.2.1 Fan control slider

#### Positions 1-2-3

Switches the phase selected by the fan *TRIAC* to three motor windings to give three different fan speeds: High/Medium/Low.

High Speed:

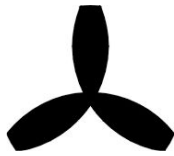

Medium Speed:

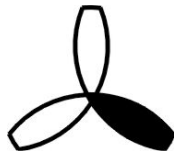

Low Speed:



#### Position 4

Indicates automatic speed (AUTOFAN) See relevant chapter

### 5.2.2 Operating mode slider

According to the model (see *table of models*), the operating mode off/*Heating*/*Cooling* or *AUTO* can be selected

Off mode:



*Heating* mode:



*Cooling* mode:



*AUTO* mode:

**AUTO**

### 5.3 LEDs

The device has 3 *LEDs*



LED1 yellow



LED 2 green



LED red



#### 5.3.1 Table of Functions and Indications associated with LEDs

Function	LED1 YELLOW	LED2 GREEN	LED3 RED
<i>Cooling</i> plus thermostat request	ON	ON	OFF
<i>Heating</i> plus thermostat request	ON	OFF	ON
Operating in Refrigeration mode	OFF	ON	OFF
Operating in <i>heating</i> mode	OFF	OFF	ON
<i>Hot Start</i> on	ON	OFF	flashing
<i>Too Cool</i> on	ON	flashing	OFF
Probe error	flashing	flashing	flashing

The 3 *LEDs* are used to indicate the mode that the controller is operating in:

**Thermostat Request LED: (YELLOW)**

Permanently on during normal operating;

**Cooling LED: (GREEN)**

It comes on when there is a *cooling* request.

Flashing: indicates that the temperature controller is not satisfied but the water temperature probe has not given permission to start the fan.

Permanently on: *cooling* available (fan and *valve* on).

**Heating LED: (RED)**

It comes on when there is a *heating* request.

Flashing: indicates that the temperature controller is not satisfied but the water temperature probe (2 pipe model) has not given permission to start the fan.

Permanently on: *heating* is available (fan, *valve* and/or *electric heaters* are on).

**NOTE:**

- All *LEDs* will flash for three seconds when the controller is switched on.

**Alarm signalling**

All *LEDs* continue to flash to indicate a state of alarm.

An alarm is emitted if the air *control* probe is damaged, disconnected or short circuits until the problem is resolved.

## 6 TEMPERATURE CONTROL FUNCTIONS

### 6.1 Operating modes

According to the models and options available, **FCPLUS** works in the following *operating modes*:

#### Operating modes

- **COOLING** (summer setting)
- **HEATING** (winter setting)
- **AUTO** (automatic selection of summer – winter setting)

#### Cooling

**Cooling**: this is the "summer" operating mode; the unit is configured to generate cold air.  
**NOTE: COOLING** ↔ "summer" setting are used synonymously

#### Heating

**Heating**: this is the "winter" operating mode; the unit is configured to generate hot air.  
**NOTE: HEATING** ↔ "winter" setting are used synonymously

#### Auto

**Auto**: the unit is configured to switch automatically from *cooling* to *heating* and vice versa depending on the temperature values detected by the air probe.  
**NOTE: AUTO** ↔ **AUTOCHANGE OVER** are used synonymously

The *loads* controlled in the different *operating modes* are shown in the table below:

#### Operating mode table

Mode	Setting	Controlling
<b>HEATING</b>	MANUAL	<ul style="list-style-type: none"> <li>• <b>Valve</b>: water (for 2 pipe fan-coil), hot water (for 4 pipe fan-coil)</li> <li>• Fan (3 speeds set manually or automatically)</li> <li>• Electric heater (2 pipes)</li> </ul>
<b>COOLING</b>	MANUAL	<ul style="list-style-type: none"> <li>• <b>Valve</b>: water (2 pipes), hot water (4 pipes)</li> <li>• Fan (3 speeds set manually or automatically)</li> </ul>
<b>AUTO</b>	AUTOMATIC	Controlled dynamically in the following modes: <ul style="list-style-type: none"> <li>• <b>HEATING</b></li> <li>• <b>COOLING</b></li> </ul>

#### Manual change

The summer – winter setting (*Cooling – Heating*) can be manually set locally.

#### Automatic change-over

- The operating mode is automatically selected according to the temperature detected by the air temperature probe.

### 6.2 Control

**FCPLUS** controls the *loads* according to a *set point* that can be set using the knob

- with 5...35°C *range*

Depending on the model, the following temperature controllers are available:

- **TEMPERATURE CONTROLLER**: controls the *valve* in COOL/HEAT mode;
- **FAN**: controls the fans in COOL/HEAT mode;
- **ELECTRIC HEATERS**: controls the *electric heaters* in HEAT mode.

Depending on how the *dip switches* are configured (see **Installation** chapter, paragraph on **Dip Switches**), the following is determined:

#### 6.2.1 Summary of Dip Switches

##### Dip Switch 5-4

- 4 pipe device
- 2 pipe device without *electric heaters*
- 2 pipe device with *control electric heaters*
- 2 pipe device with integrated *electric heaters*

##### DIP 3

- thermostat *control* on *valve*
- thermostat *control* on fan

##### DIP 2-1

- ventilation on demand
- continuous ventilation
- floor-mounted device
- ceiling-mounted device

#### 6.2.2 Thermostat control on fan/valve

##### DIP 3

- thermostat *control* on *valve*
- thermostat *control* on fan

### 6.3 Thermostat control on valve

If this is the case, *control* of the fans varies according to the operating mode selected (Cool or Heat) and behaves as follows:

- A. in Cool mode, the fans operate at the speed selected by the fan *slider* or set by the Autofan controller and they are never deactivated unless the *Too Cool* function intervenes; the speed is the one selected by the fan *slider* (controlled in *AUTO* mode if *AUTO* has been selected)
- B. in Heat mode, the fan follows the *valve* state (observing the activation delay time) and behaves as follows:
  - i. fan ON 60 seconds after the *valve* open command (signalled by flashing of the red LED);
  - ii. fan OFF when *valve* close command is given.
  - iii. the *HOT START*, *POST VENTILATION* and *PERIODIC VENTILATION functions* are also activated (because the probe is located on the upstream side of the *valve*). (see *Functions* chapter)

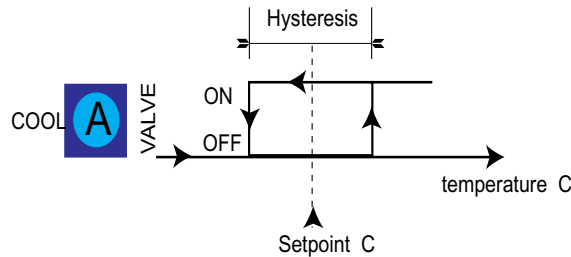
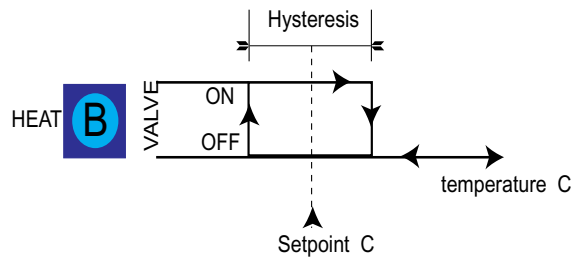

**→IF the water probe is PRESENT:**

The stop fan in *heating* mode function (*Hot Start*) will obviously always be on for water temperatures below P 08°C and the red LED will flash on and off.

If the controller is ON (fans on), the speed will be:

- manually set by the user (Min – Med – Max speeds permitted);
- set by *AUTO\_FAN* at automatic speed if the fan *slider* is positioned to *Auto* mode.

If Dip switch 2 is in the ON position, the *HOT START* function is deactivated and the fan is always on irrespective of the ambient temperature and the water temperature (in *Auto* Fan operating, the controller prevents the fan being turned off).

**6.3.1 AUTO FAN – temperature control on valve**

Speed of the fans is automatically controlled according to the *offset* between the ambient temperature and the temperature set with the *set point*.

The graphs related to fan *control* for temperature *control* on the *valve* are shown below.

**AUTOFAN COOL  
MODE  
temperature  
control on valve**

**AUTOFAN COOL MODE temperature control on valve**

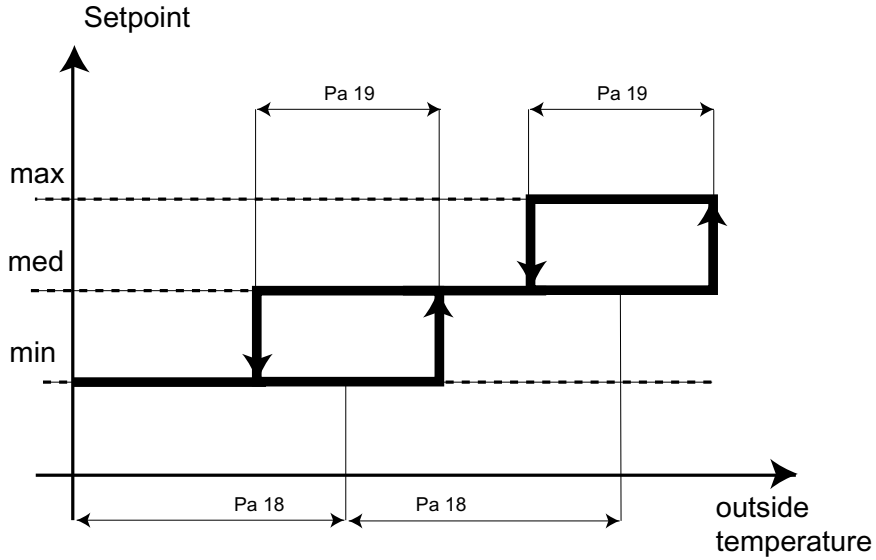

**AUTOFAN HEAT  
MODE  
temperature  
control on valve**

**AUTOFAN HEAT MODE temperature control on valve**

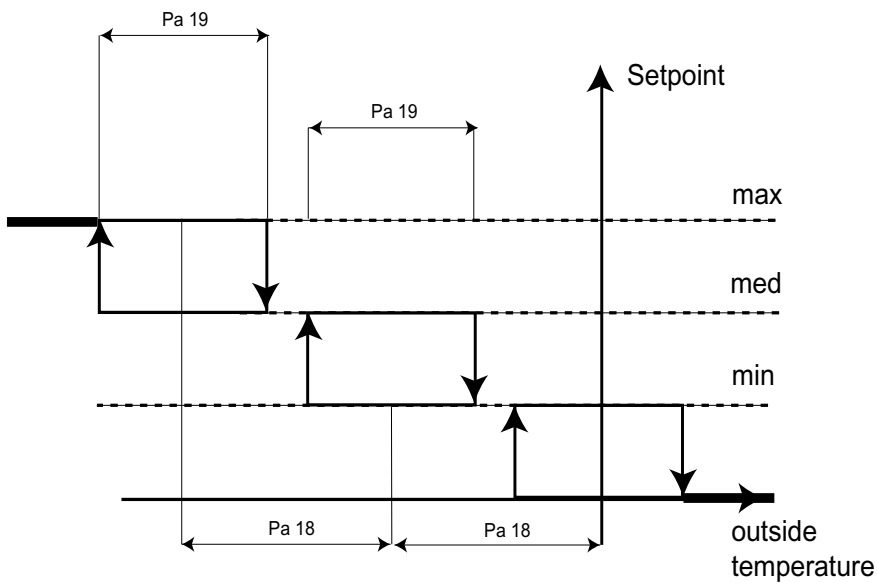

**Note:** the *Set point* label in the axis of abscissas in the above graphs refers to the *Set point* value set by the user using the potentiometer.

The step intervention differential is equal to parameter 18 and the intervention *hysteresis* equals parameter 19.

**6.3.2 Thermostat control on fan**

This type of temperature *control* only uses the fans, the *valve* is not used (the hot or cold water goes into the coil inside the Fan Coil), and the temperature controller works by enabling or inhibiting fan consent (observing the Heat and Cool *set points*).

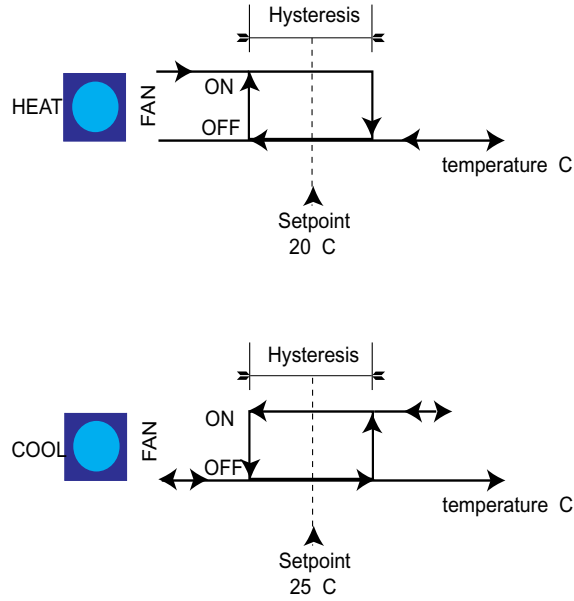

The fans are controlled in the same way as the valves using the same *set points* and the same *hysteresis*.

If the controller is ON (fans on), the speed will be:

- manually set by the user (Min – Med – Max speeds permitted);
- set by *AUTO\_FAN* at automatic speed if the fan *slider* is positioned to *Auto* mode.

With thermostat *control* on fans the *Periodic Ventilation*, *Hot Start* and *Too Cool functions* are activated. (see *Functions chapter*)

**6.3.3 AUTO FAN with temperature control on fan**

Speed of the fans is automatically controlled according to the *offset* between the ambient temperature and the temperature set with the *set point*.

The graphs related to fan *control* for temperature *control* on the fan are shown below.

AUTOFAN COOL  
MODE  
temperature  
control on fan

AUTOFAN COOL MODE temperature *control* on fan

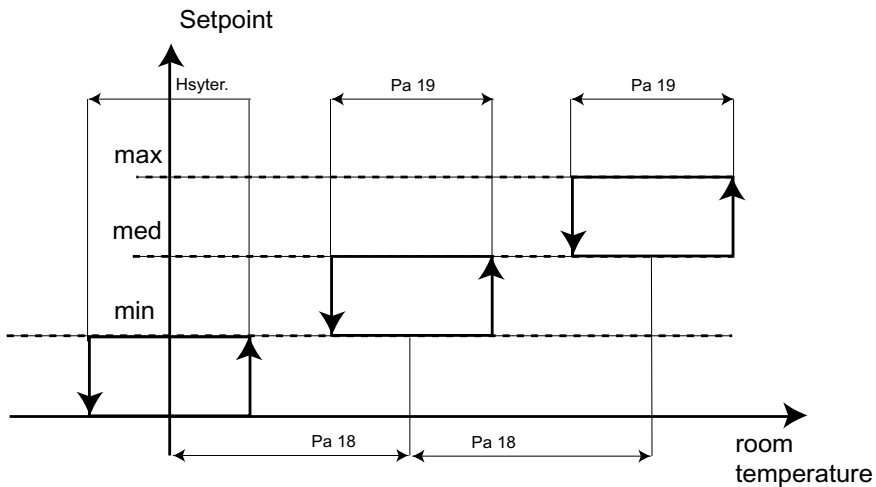

AUTOFAN HEAT  
MODE  
temperature  
control on fan

AUTOFAN HEAT MODE temperature *control* on fan

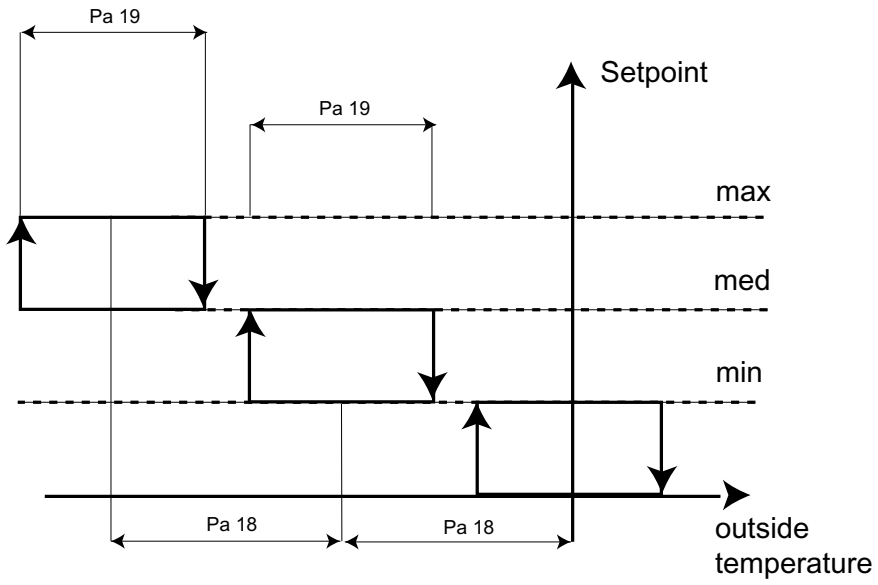

Ventilation with *electric heaters* and *post ventilation*

If the *electric heaters* are present and activated (both integrated and regulated), the fan speed is forced to maximum speed and the fan must switch itself off with a delay equal to parameter 07 after the last shut down of the *electric heaters*.

### 6.3.4 Load control

#### Dip Switch 5-4

- 4 pipe device
- 2 pipe device without *electric heaters*
- 2 pipe device with *control electric heaters*
- 2 pipe device with integrated *electric heaters*

The status of *outputs* OUT1 e OUT2 varies according to the type of device:

The status shown in the table refers to when the temperature controller is not satisfied; if the controller is satisfied, the output marked as ACTIVE in the table would be INACTIVE.

type of machine	output (OUT)	HEAT	COOL
2 PIPES Without <i>electric heaters</i>	OUT1	OUTPUT ACTIVE	OUTPUT ACTIVE
	OUT2	-	-
2 PIPES <i>Control electric heaters</i>	OUT1	-	OUTPUT ACTIVE
	OUT2	OUTPUT ACTIVE	-
2 PIPES Integrated <i>electric heaters</i>	OUT1	OUTPUT ACTIVE	OUTPUT ACTIVE
	OUT2 [VALVE] [RES.]	OUTPUT ACTIVE IF $T_{H_2O} < Pa\ 05 - Pa06$ OUTPUT INACTIVE IF $T_{H_2O} > Pa\ 05$	-
4 PIPES	OUT1	Not used	OUTPUT ACTIVE
	OUT2	OUTPUT ACTIVE	-

#### NOTE:

- indicates NOT USED

### 6.3.5 Electric heaters

#### Dip Switch 1-2

- 2 pipe device with *control electric heaters*
- 2 pipe device with integrated *electric heaters*

The *electric heaters* can work

- in *Control* mode
- in Integration mode

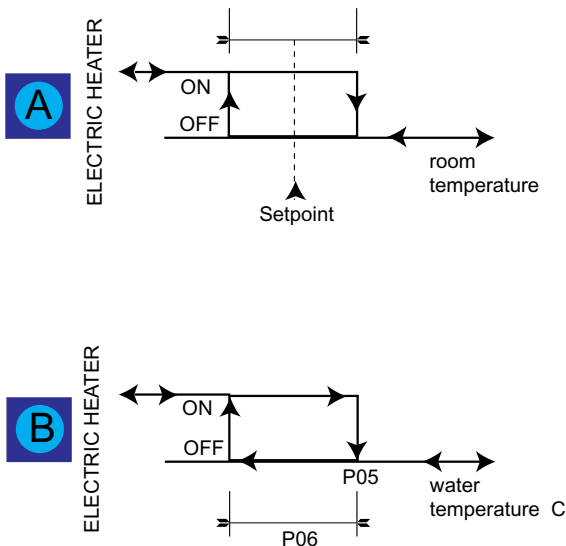

If *control electric heaters* are required, the heat is only controlled by the *electric heaters* and corresponds to the HEAT step on the diagrams (**point A**)

If this is the case, the digital output OUT2 is used to drive (indirectly using a suitable relay) a electric heater coil.

If integrated *electric heaters* are to be used, the controller will use (**point B**)

- water and *electric heaters* if the temperature of the H<sub>2</sub>O is lower than Pa 05 – Pa06 (°C);
- water if the temperature of the H<sub>2</sub>O is higher or equal to Pa 05 °C; *hysteresis* equal to Pa 06 °C is applied

## 7 FUNCTIONS

### 7.1 Automatic Change over

#### Type of system

- 2 pipe device
- 4 pipe device

#### Mode

- *Heating/Cooling*

The *Automatic Change-over* function (**AUTO-CHANGE OVER**) automatically selects the *Heating/Cooling* mode according to the ambient temperature and enables the controller to *control* machine operating independently.

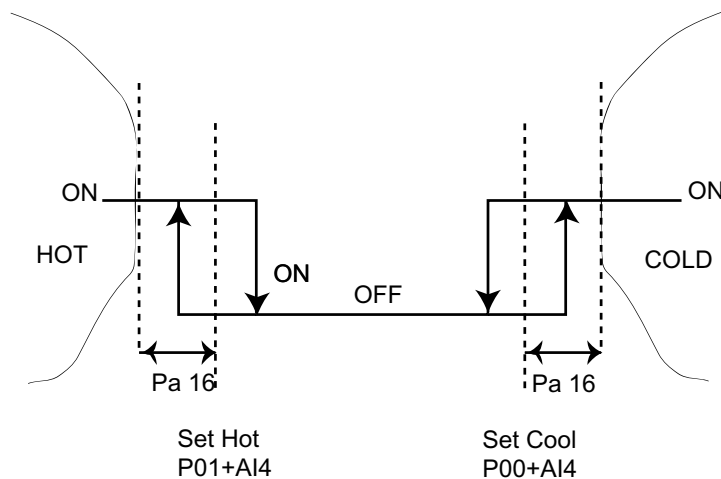

(\*\*)

- The Heat mode is selected if:  
value read by the ambient probe (*control* or remote) < **Heat set point for change-over** (according to *set point* in *Heating* + delta changeover)
- The Cool mode is selected if:  
value read by the ambient probe (*control* or remote) < **Cool set point for change-over** (according to *set point* in *Heating* + delta changeover)

As soon as the machine goes into *Auto Change Over* mode (at start-up or from another mode) ventilation is forced into medium speed with duration set by the parameter (fan duration for change-over).

- during ventilation all resources (except for fans) stay OFF;
- the *LEDs* stay as they were for the previous state.

When ventilation is completed, the controller establishes which mode to go into according to \*\*.

If the temperature value falls within the “*dead zone*”, the controller will remain in the mode that it was in prior to the selected phase.

If the main temperature controller is satisfied for a minimum period equal to the change-over delay time **Periodic ventilation**\*\*\* is effected.

When the On period has terminated, the controller verifies the presence of change-over conditions.

\*\*\*OFF periods specified by P20 (*Automatic change-over* delay)

and On periods specified by parameter P25 (fan duration for change-over),

The fan OFF time meter is reloaded each time the On period is completed and each time the temperature controller is not satisfied; OFF time begins when the temperature controller is satisfied.

If the ambient temperature falls within the *dead zone* (OFF area on graph) at Power-ON, the board goes into the condition prior to Power-OFF (or if it was in Heat mode, it stays in this condition).

The fans behave in the same way as cases of manual Heat/Cool operating.

#### Decalibration of *Set point* (see relevant paragraph)

The temperature controller *set points* are determined by the decalibration caused by ceiling or floor-mounted *installation*.

the temperature value for entering a mode refers to the non-decalibrated *set point*

## 7.2 Hot Start

### Type of system

- 2 pipe device if no electric heaters
- 4 pipe device

### Mode

- Heating

### Dip Switches

- Dip 2=OFF binding condition
- Dip 4=OFF binding condition
- 

**NOTE: PRESENCE OF WATER PROBE (REMOTE) NECESSARY** (see [diagram of water probe mounted downstream](#))

The **Hot Start** function stops cold air from entering the winter operating environment.

Its involves preheating the exchanger (*finned coil*) before activation of fans.

Ventilation will only start when the water probe detects a temperature above (Pa 08) degrees °C.

If this does not occur, it waits for permission from the probe.

If the **WATER** probe is not present (or is faulty):

- the **HOT START** is ignored and the fans follow normal temperature *control*.

### LED signalling

While the **Hot Start** delay is in progress (controlled by the timer or water probe), the red LED (*heating*) will continue to flash quickly.

Once the delay is over and the fan has started, the red LED remains permanently ON.

### Function active if...

This function is only active in *heating* mode.

The **Hot Start** function controlled by the "temperature" is only available in the models with a water probe for:

- 2 pipe systems without electric heater
- 4 pipe systems

### Water probe

The water probe (*analogue inputs*) must always be mounted on the water pipe on the downstream side of the *valve* and as near as possible to the coil. In 4 pipe systems, it must always be mounted on the hot water and not the cold water circuit.

diagram of water  
probe mounted  
downstream

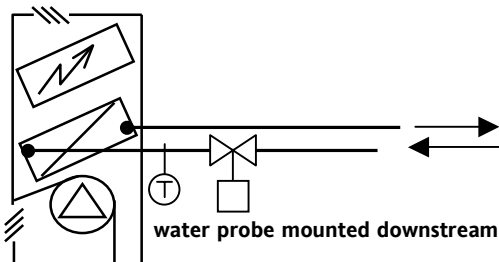

### 7.3 Too Cool

#### Type of system

- 2 pipe device

#### Mode

- *Cooling*

#### Dip Switches

- Dip 4=OFF

**NOTE: PRESENCE OF WATER PROBE (REMOTE) NECESSARY** (see *diagram of water probe mounted downstream*)

The *Too Cool* function stops hot air from entering the summer operating environment.

It involves activating the fans when the water temperature is sufficiently cold.

Ventilation will only start when the water probe detects a temperature that is lower than or equal to **(Pa 08) degrees °C**.

If the probe is not present (or is faulty):

- ventilation is activated as in normal temperature *control*.

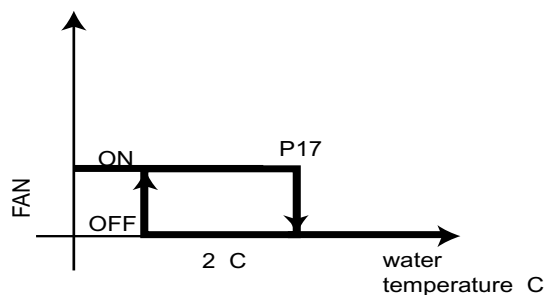

**NOTE:** There is fixed *hysteresis* for *valve control* of 2°C

#### 7.3.1 Blocking Hot-Start and Too- Cool functions from Power –On.

The *Too-Cool* and *Hot-Start* *functions* are disabled by default when powering on for the first time

At the first Power-On, irrespective of the water temperature, the fans operate at the speed set by the fan *slider*; the *Hot-Start* and *Too-Cool* *functions* are ignored.

This function allows the installer to test the fans once the machine is installed without having to wait for the water temperature to give permission for them to be activated.

This block is active for approximately 10 minutes.

When the machine is powered, two cases may arise:

- If power supply is cut off while the time is being counted (within 10 minutes), the counter is reset at the next Power-ON and the fans operate as described above.
- If the counter goes to zero (10 minutes or more have elapsed), the *Hot-Start* and *Too-Cool* *functions* remain active even if the device is switched off

### 7.4 Periodic ventilation

#### Type of system

- 2 and 4 pipe device

#### Mode

- *Heating* and *Cooling*

#### Dip Switches

- Dip 4=OFF

If the ventilation is not activated by a parameter-set period (according to whether it is floor or ceiling-mounted), it is activated for a parameter-set period at the end of the cycle so that the air on the ambient air probe is recycled.



This is to prevent stratification of the air in the premises that would give an inaccurate reading of the air temperature.

The tables below indicate the duration and frequency of the cycles;

- during the ON cycles, the fan speed is set to MINIMUM.
- at each change-over (Heat →Cool, Cool →Heat, OFF→ Cool, OFF →Heat) the start-up of the fans is forced to Minimum speed for a parameter specified duration

#### 7.4.1 Fan activation cycles in HEAT Mode

Difference between ambient temp. and <i>set point</i>	Activation cycles	
	OFF	ON
Floor-mounted configuration	Pa 10	Pa 13
Ceiling-mounted configuration	Pa 11	Pa 14

#### 7.4.2 Fan activation cycles in COOL Mode

Difference between ambient temp. and <i>set point</i>	Activation cycles	
	OFF	ON
Floor and ceiling-mounted configuration	Pa 12	Pa 15

### 7.5 Post Ventilation

#### Type of system

- *electric heaters* present
- 2 pipe device

#### Mode

- *Heating*

The fan continues to operate for (Pa 07) minutes after deactivation of the *electric heaters*.



This function prevents overheating in the fan-coil unit and protects the *electric heaters*.

### 7.6 Set point Decalibration

#### Type of *installation*

- ceiling-mounted installations

#### Mode

- *Heating*

If the ceiling-mounted configuration is selected (with dip-switch 1) the *set point* in the heat mode is increased by a value equal to (Pa 21)

---

#### Type of *installation*

- floor-mounted *installation*

#### Mode

- *Cooling*

If the floor-mounted configuration is selected (with dip-switch) the *set point* in the cool mode is increased by a value equal to (Pa 28)

### 7.7 Economy / Window Contact

#### Models

- *FPU32E/B: Economy (E) function available*
- *FPU32E/S: Economy (E) function available*
- *FPU32W/B: Window Contact (W) function available*
- *FPU32W/S: Window Contact (W) function available*

#### 7.7.1 Economy (E)

The Economy mode can be selected by way of a 24V~ power supply (digital voltage input) in the dedicated terminals (see *wiring diagrams*).

This function “shifts” the *set point* as described below.

- In *HEATING* mode (winter setting): the *set point* is (Pa 27) °C



- In **COOLING** mode (winter setting): the *set point* is (Pa 26) °C

This function can be used to save energy consumption, at night time or during a holiday period, for example.

### 7.7.2 Window Contact (W)

By way of a window contact, the controller can be put on *stand-by* when the window contact is at 24V~. The aim of this function is to avoid wasting energy when the window is opened by staff.

This function “shifts” the *set point* as described below.

- In **HEATING** mode (winter setting): the *set point* is (Pa 27) °C
- In **COOLING** mode (winter setting): the *set point* is (Pa 26) °C

The contact **MUST** be energized.

## 8 PARAMETERS

*Parameters* can be set so that the *FCPLUS* is fully configurable.

- They are factory-set and CANNOT therefore be modified.

### 8.1 Table of configuration constant values (parameters)

The following table indicates the *FCPLUS*'s configuration constant values (*parameters*) referred to in previous chapter, in this manual. The controller does NOT have an *interface* with a display. For this reason, the end-user cannot see these values and they cannot be set during *installation* of the product.

- The Number column indicates the sequential number of the parameter
- The Par. column indicates the parameter name
- The Description column indicates the parameter function
- The LOW\_LIM column indicates the Parameter's Lower Limit
- The HIGH\_LIM column indicates the Parameter's Upper Limit
- The U.M. column indicates the unit of measurement of the parameter
- The Models column indicates the default value (non-modifiable) of the parameter for each model

According to the relevant model, check the default value of the parameter that you want the configuration value for: e.g. the Economy *Set point* in *Cooling* (Pa 26) for model FCU32E/B is 28°C whereas it is 35°C for model FCU32W/B

The following table summarizes all the *FCPLUS parameters*.

Index	Par.	Description	LOW_LIM	HIGH_LIM	U.M	Models					
						U320/B	U32W/B	U32E/B	U320/S	U32W/S	U32E/S
1	PA00	<i>Set point Cooling</i>	100	500	°C	20	20	20	20	20	20
2	PA01	<i>Set point Heating</i>	100	500	°C	20	20	20	20	20	20
3	PA02	<i>Offset on knob for Cooling/Heating set point</i>	0	150	°C	15	15	15	15	15	15
4	PA03	<i>Hysteresis</i> if built-in air temp. sensor	0	100	°C	0.4	0.4	0.4	0.4	0.4	0.4
5	PA04	<i>Hysteresis</i> if remote air temp. sensor	0	100	°C	0.4	0.4	0.4	0.4	0.4	0.4
6	PA05	<i>Set point</i> electric heater (supplementary)	100	1000	°C	41	41	41	41	41	41
7	PA06	<i>Hysteresis</i> electric heater (supplementary)	0	100	°C	2	2	2	2	2	2
8	PA07	<i>Post ventilation</i> time (electric heater)	0	255	Sec	35	35	35	35	35	35
9	PA08	<i>Set point HOT START</i>	100	500	°C	2	2	2	2	2	2
10	PA09	Delay ON Fan-Valve <i>Heating</i>	0	255	Sec	25	25	25	25	25	25
11	PA10	OFF time periodic fan <i>Heating</i> (Floor)	0	255	Min	1	1	1	1	1	1
12	PA11	OFF time periodic fan <i>Heating</i> (Ceiling)	0	255	Min	1	1	1	1	1	1
13	PA12	OFF time periodic fan <i>Cooling</i>	0	255	Min	0	0	0	0	0	0

### Configuration parameters

14	PA13	ON time periodic fan <i>Heating</i> (Floor)	0	255	Sec	-2	-2	-2	-2	-2	-2	-2
15	PA14	ON time periodic fan <i>Heating</i> (Ceiling)	0	255	Sec	35	35	28	35	35	35	28
16	PA15	ON time periodic fan <i>Cooling</i>	0	255	Sec	5	5	14	5	5	5	14
17	PA16	Differential <i>AUTO</i> mode	0	250	°C	0	0	0	0	0	0	0
18	PA17	<i>Set point TOO COOL</i>	0	2550	°C	0	0	0	0	0	0	0
19	PA18	Autofan speed differential	0	100	°C	20	20	20	20	20	20	20
20	PA19	Autofan speed <i>hysteresis</i>	0	100	°C	60	60	60	60	60	60	60
21	PA20	Delay <i>AUTO</i> mode change mode	0	255	Min	10	10	10	10	10	10	10
22	PA21	<i>Offset set point Heating</i> (Ceiling)	0	250	°C	10	10	10	10	10	10	10
23	PA22	<i>Offset</i> remote air temp. sensor	-128	127	°C	10	10	10	10	10	10	10
24	PA23	<i>Offset</i> water temp. sensor	-128	127	°C	30	30	30	30	30	30	30
26	PA25	Ventilation time for change mode ( <i>AUTO</i> )	0	255	Sec	30	30	30	30	30	30	30
27	PA26	<i>Set point</i> Economy <i>Cooling</i>	100	500	°C	30	30	30	30	30	30	30
28	PA27	<i>Set point</i> Economy <i>Heating</i>	0	500	°C	30	30	30	30	30	30	30
29	PA28	<i>Offset set point Cooling</i> (floor)	-128	127	°C	30	30	30	30	30	30	30

\_\_\_\_\_

## 9 TECHNICAL DATA

### 9.1 Technical Data

#### 9.1.1 FCPLUS General Technical Data

	Wall-mounted version		
	Typical	Maximum	Minimum
Supply voltage	230V~	253V~	207V~
Electrical data for 230V output	0.5 A max for <i>valve outputs</i> and 1 A max for fan <i>outputs</i>		
Maximum power consumption	12W	12W	12W
Insulation class	II	II	II
Degree of protection	IP30	IP30	IP30
Operating ambient temperature	25°C	55°C	0°C
Operating ambient temperature*	30%	90%	10%
Storage temperature	55°C	85°C	-20°C
Storage humidity*	30%	90%	10%

\*(non-condensing)

#### 9.1.2 FCPLUS I/O Technical Data

	TOT	No.	THERMOSTAT
<i>Analogue Inputs</i>	3	1	air probe on <i>control</i>
		1	1 remote air probe (optional): cover 4.7 X 27 mm; plastic resin tube; length of cable: 1.5 m
		1	remote water probe (optional): cover 6 X 23 mm; plastic resin tube; length of cable: 2 m
<i>Digital Inputs</i>	4+4	4	SLIM switch <i>inputs</i> (off/summer/winter/ <i>auto_mod</i> e)
		4	SLIM switch <i>inputs</i> (min/med/max/ <i>auto_fan</i> )
<i>Dip Switches</i>	5	5	dip switch
<i>Digital Outputs</i>	5	5	<i>outputs</i> for <i>valve</i> and fan <i>control</i>
<i>LEDs</i>	3	3	<i>LEDs</i> (SUMMER /WINTER/ REQUEST)

#### 9.1.3 FCPLUS Mechanical Technical Data

Unit dimensions	80x120x40 mm
<i>Mounting*</i> (floor or ceiling)	wall-mounted using the base as a drilling template, device-mounted (floor or ceiling)
Colour of casing	<ul style="list-style-type: none"> <li>• Keypad: white;</li> <li>• Base unit: white.</li> </ul>
<i>Connections</i>	screw terminal block for wires with 2.5 mm <sup>2</sup> maximum diameter
Compliance	CE LV-EMC

**\*Note:**

- you can distinguish between wall-mounted and device-mounted versions by checking to see if a remote air probe is present or not.
- If there is no probe, it is a wall-mounted model.

9.2 Dimensions (mm)

front view

*front view*

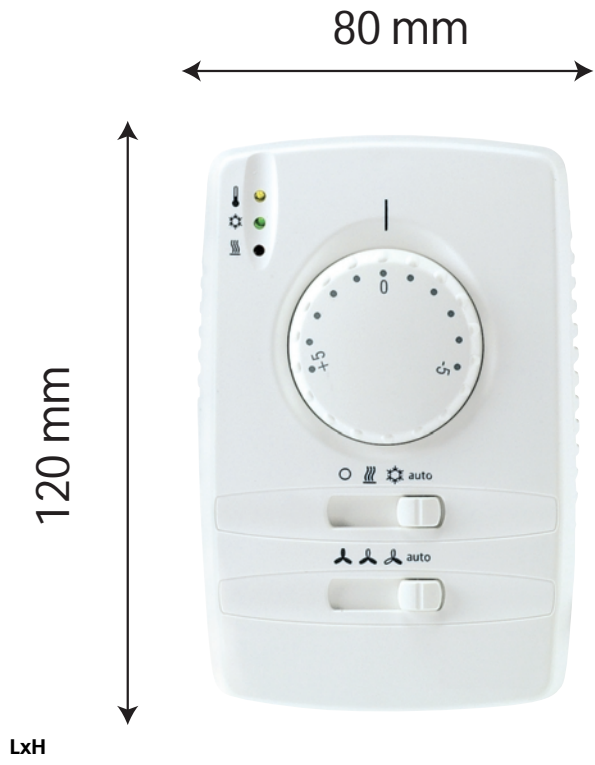

side view

*side view*  
HxD



### 9.3 Declaration of compliance

The device has been designed to be used in electromechanical systems in the air conditioning sector and in devices called fan-coils in particular.

All relevant parts of the directive on low voltage that concern the stated application field must be complied with.

The product complies with the following European Union Directives:

- **EU Directive 73/23/EEC and subsequent amendments**
- **EU Directive 89/336/EEC and subsequent amendments**

and is compliant with the following harmonized standards:

- **LOW VOLTAGE: EN 60730**
- **EMISSIONS: EN 50081-1 (EN 55022)**
- **IMMUNITY: EN 50082-1 (CEI 801-2-3-4-5-11)**

**Note1:** if the device is used as a component, compliance with the directives is guaranteed for the board but not certification of the machine on which it is installed. The latter is the manufacturer's responsibility.

**Note:** since all the electrical parts of the instrument are subjected to dangerous voltage levels (not at low safety voltage, SELV), reinforced probes must be used.

## 10 USE OF DEVICE

### 10.1 Permitted Use

- For safety purposes, the device must be installed and used in accordance with the instructions supplied. Users must not be able to access parts with dangerous voltage levels under normal operating conditions. The unit must be resistant to water and dust, depending on the application, and only be accessible using special tools.  
**The use of the unit for applications other than those described is forbidden.**

## 11 RESPONSIBILITY AND RESIDUAL RISKS

Eliwell & Controlli srl shall not be held liable for any damage incurred as a result of:

- *installation*/use other than those intended, and, in particular, failure to comply with the safety instructions specified by applicable regulations and/or provided in this document;
- use with equipment which does not provide adequate protection against electric shocks, water and dust under the effective conditions of *installation*;
- use with equipment which permits access to hazardous parts without the use of tools;
- *installation*/use with equipment which does not comply with current regulations and legislation.

## 12 DISCLAIMER

This manual and its [contents](#) remain the sole property of **Eliwell & Controlli srl** and shall not be reproduced or distributed without authorization. Although great care has been exercised in the preparation of this document, **Eliwell & Controlli srl**, its employees or its vendors, cannot accept any liability whatsoever connected with its use **Eliwell & Controlli srl** reserves the right to make any changes or improvements without prior notice.

## 13 GLOSSARY

<b>Stand-by</b>	Means that the unit is in waiting mode and that all the <i>functions</i> are temporarily suspended.
<b>Blinking</b>	It means intermittent blinking; it usually refers to <i>LEDs</i>
<b>Lighting up</b>	Means to light up. This term generally refers to <i>LEDs</i> .
<b>Loads</b>	These identify the various devices in a plant such as compressors, fans, hydraulic pump and <i>electric heaters</i> .
<b>Set point</b>	This represents the reference value (that can be set by the user) that defines the operating status of the plant. A typical example is the thermostat that regulates the temperature in our homes. To maintain a temperature of 20 °C, we must set the <i>set point</i> at 20°C (the <i>heating</i> system will start if the ambient temperature measured is below 20°C, if not, it will be turned off).
<b>Dead zone</b>	This refers to the area between the <i>heating</i> and <i>cooling set points</i> in which the controller <i>outputs</i> remain deactivated. The controller is on " <i>stand-by</i> ".
<b>Range</b>	This represents a set of values. <i>Range</i> 5...35 includes all the values between 5 and 35.
<b>Hysteresis</b>	<p><i>Hysteresis</i> (also called "switching differential") is generally defined in connection with a <i>set point</i> to avoid frequent oscillations in the status of the controlled load.</p> <p>Example: let's define a <i>set point</i> of 20 °C on a probe that detects ambient temperature so that the compressor starts every time the limit value is exceeded.</p> <p>When ambient temperature reaches values that are close to the <i>set point</i> (20°C), a phase of instability occurs during which the relay, which starts the compressor, frequently changes its status from ON to OFF. This condition can severely damage the plant.</p> <p>To avoid this problem, <i>hysteresis</i> is defined: a tolerance <i>range</i> in which there is no change of status. In our example, we could set a <i>hysteresis</i> of 1° C. This means that the compressor is activated at 21°C (<i>set point</i> + <i>hysteresis</i>) and deactivated at 19°C (<i>set point</i> - <i>hysteresis</i>)</p>
<b>Non volatile memory</b>	This memory stores data even when the unit is turned off (as opposed to a volatile memory that deletes data as soon as the unit is turned off).
<b>Change over</b>	This term indicates the switching of an operating mode (example: from <i>Cooling</i> to <i>Heating</i> or vice versa).
<b>Offset</b>	It usually defines a value to be added to or subtracted from another value, a <i>set point</i> , for example, that compensates.
<b>Slider</b>	A slide switch used to change the state of a device manually or select a mode.

\_\_\_\_\_

2	
2 pipe system	6
4	
4 pipe system	6
<b>A</b>	
Accessories	8
Alarm signalling	22
Analogue inputs	14
Analogue inputs/Probes	14
Auto	23
AUTO FAN – temperature control on valve	25
AUTO FAN with temperature control on fan	26
<b>AUTOFAN COOL MODE temperature control on fan</b>	26
AUTOFAN COOL MODE temperature control on valve	25
<b>AUTOFAN HEAT MODE temperature control on fan</b>	27
AUTOFAN HEAT MODE temperature control on valve	25
<b>Automatic Change over</b>	29
Automatic change-over	23
<b>B</b>	
<b>Blocking Hot-Start and Too- Cool functions from Power –On.</b>	31
<b>C</b>	
Change over	43
Characteristics for selecting product models:	8
Characteristics of machine	16
Clicking of selector knob	19
Configuration parameters	34
Connections	11
CONTENTS	2
<b>Control</b>	23
Control of Fan	7
Control of range	19
Cooling	23
<b>Cross references</b>	4
<b>D</b>	
Dead zone	43
Declaration of compliance	39
diagram of water probe mounted downstream	30
Digital outputs	15
Dimensions (mm)	38
<b>Dip 3</b>	18
DIP 3 Configuration	18
<b>Dip 4-5 configuration</b>	17
Dip Switch Configuration	17
<b>Dip Switches</b>	9; 15
DISCLAIMER	42
<b>E</b>	
Economy (E)	32
<b>Economy / Window Contact</b>	32
Electric heaters	7; 28
Example of fan-coil system	6
<b>F</b>	
<b>Fan activation cycles in COOL Mode</b>	32
Fan activation cycles in HEAT Mode	32
Fan control slider	21
FC PLUS	13
<b>FC PLUS Models</b>	7
<b>FCPLUS</b>	5; 6
FCPLUS General Technical Data	37
FCPLUS I/O Technical Data	37
FCPLUS interface	6
FCPLUS Mechanical Technical Data	37
Finned coil	7
<b>FP U320S</b>	13
<b>FPU32E/B</b>	13
<b>FPU32E/S</b>	13
<b>FPU32W/B</b>	14
<b>FPU32W/S</b>	14
<b>front view</b>	38
FUNCTIONS	29
<b>G</b>	
General Description	5
GLOSSARY	43
<b>H</b>	
Heating	23
Hot Start	30
How to order FCPLUS	7
HOW TO USE THIS MANUAL	4
Hysteresis	43
<b>I</b>	
Icons for emphasis:	4
Inputs	13
INSTALLATION	10
Interface	6
INTRODUCTION	5
<b>Item Code</b>	7
<b>L</b>	
LEDs	21
Lighting up	43
<b>Load control</b>	28
Loads	43
<b>M</b>	
Manual change over	23
Models available	7
Mounting	10
<b>N</b>	
Non volatile memory	43
NTC temperature probe, plastic cover 7x25, reinforced insulation, PVC cable, cable length = 1.5m	8

<b>O</b>	
Offset .....	43
Operating mode slider .....	21
<b>Operating mode table</b> .....	23
Operating modes .....	23
Outputs .....	11
<b>P</b>	
PARAMETERS .....	34
<b>Periodic ventilation</b> .....	31
Permitted Use .....	40
<b>Post Ventilation</b> .....	32
<b>R</b>	
Range .....	43
Recommendations .....	10
<b>References</b> .....	4
Remote water and air probe .....	8
<b>RESPONSIBILITY AND RESIDUAL RISKS</b> .....	41
<b>S</b>	
Set point .....	43
<b>Set point Decalibration</b> .....	32
Set point selector knob - FC PLUS .....	19
<b>side view</b> .....	38
Slider .....	43
Sliders .....	20
Stand-by .....	43
<b>Summary of Dip Switches</b> .....	23

<b>T</b>	
Table of configuration constant values (parameters) .....	34
Table of FCPLUS characteristics .....	8
Table of Functions and Indications associated with LEDs .....	21
Table of models .....	7
Technical Data .....	37
TECHNICAL DATA .....	37
TEMPERATURE CONTROL FUNCTIONS .....	23
Temperature set point .....	15
Terminal block diagram .....	11
Thermostat control on fan .....	26
<b>Thermostat control on fan/valve</b> .....	23
Thermostat control on valve .....	24
Too Cool .....	31
TRIAC .....	15
<b>U</b>	
USE OF DEVICE .....	40
<b>USER INTERFACE</b> .....	19
<b>V</b>	
Valve .....	7
<b>W</b>	
Window Contact (W) .....	33
Wiring diagrams .....	11
Wiring recommendations .....	11



Eliwell & Controlli s.r.l.  
 Via dell'Industria, 15 Zona Industriale Paludi  
 32010 Pieve d'Alpago (BL) ITALY  
 Telephone +39 0437 986111  
 Facsimile +39 0437 989066  
 Internet <http://www.eliwell.it>

Climate Controls Europe  
 An Invensys Company

